

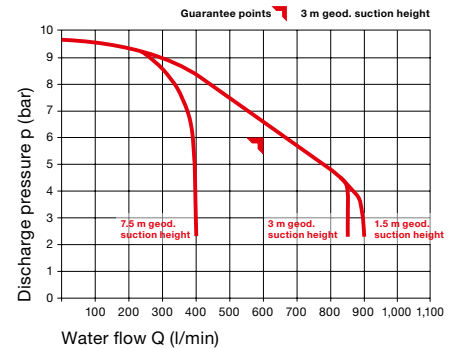

PORTABLE PUMP PFPN 6-500-2 – ULTRA COMPACT

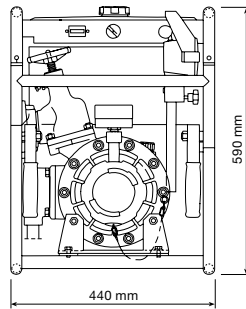
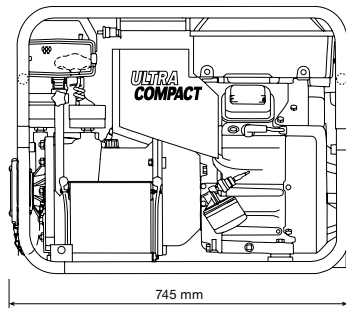

engine	Briggs & Stratton 2-cylinder 4-stroke V-engine, displacement 570 cm ³
output	13 kW (18 HP) at 3600 rpm
ignition system	electronic contactless magneto ignition, maintenance-free
start unit	electric starter with battery and recoil starter for manual emergency start
fuel	8.5 l fuel tank for non-leaded or leaded regular gasoline (min. 85 ROZ)
dimensions	L x W x H: 745 x 440 x 590 mm
weight	ready for action: approx. 96 kg
power transmission	automatic centrifugal clutch
pump	two-stage ZIEGLER centrifugal fire pump FPN 6-500-2 acc. to DIN EN 1028
nominal output	500 l/min at 6 bar and 3 m geod. suction height
pump output	<ul style="list-style-type: none"> ▪ 800 l/min at 4 bar and 3 m geod. suction height ▪ 650 l/min at 6 bar and 3 m geod. suction height ▪ 400 l/min at 8 bar and 3 m geod. suction height ▪ 900 l/min at 2 bar and 1.5 m geod. suction height ▪ 380 l/min at 6 bar and 7.5 m geod. suction height
pump connection	<ul style="list-style-type: none"> ▪ suction side: suction inlet with B tight coupling and B blank cap, Storz system ▪ delivery side: B delivery outlet, lockable, with B tight coupling, Storz system
gauges and controls	<ul style="list-style-type: none"> ▪ manometer and mano-vacuummeter acc. to DIN 14421 ▪ control panel with turning handle for "throttle", stop button, ignition switch, working hour recorder, oil pressure control lamp
pump materials	water-bearing parts: seawater resistant light alloy, pump shaft and split water rings: stainless steel
priming system	TROKOMAT PLUS
lighting	halogen searchlight 12 V / 55 W, extendible
carrying frame	high-strength light metal frame with four foldable grips