



Identical in all Ziegler fire pumps

We install the Ziegler TROKOMAT PLUS in all vehicle fire pumps and in all portable pumps from type PFPN 6-500 onwards, i.e. in all these types of pumps TROKOMAT PLUS parts and functions are identical.



GOOD REASONS, TO CHOOSE TROKOMAT:

- Fully automatic priming system: TROKOMAT PLUS
- The TROKOMAT PLUS operates without any auxiliary fluids.
- The TROKOMAT PLUS is switched on and off hydraulically by means of water pressure and no other control is required.
- Even at low engine rpm the TROKOMAT PLUS starts the suction action.
- Immune to interference by using a few components
- Compact construction. Installed in all vehicle pumps and portable pumps from PFPN 6-500 onwards.



Albert Ziegler GmbH, Memminger Straße 28, 89537 Giengen/Brenz, Germany
 Mail ziegler@ziegler.de, Phone +49 7322 951-0, Fax +49 7322 951-211,
www.ziegler.de

The information may contain accessories and special equipment, that are not part of the standard delivery. Subject to technical modifications. For misprints we accept no liability. 200/961/4/0415

FULLY AUTOMATIC AND SECURE. OUR TROKOMAT PLUS.

Automatic priming systems, that set standards!



OUR TROKOMAT PLUS: POWERFUL & SECURE!

ADVANTAGES OF THE TROKOMAT PLUS PRIMING SYSTEM:

- Compact construction. Installed in all vehicle pumps and portable pumps from PFPN 6-500 onwards.
- It operates without any kind of auxiliary controlling device, thus particularly wear-resistant and maintenance free.
- Automatic switch-off when the pump delivers water.
- The insensibility to dirty water has been further improved.
- Improved suction times.
- Improved dry-running ruggedness.
- Geod. suction height up to 8.5 m.



DESIGN & MODE OF OPERATION.

The Ziegler TROKOMAT PLUS is a modern reciprocating priming pump that carries out the priming action fully automatically, thus simplifying the pump operation to a minimum. The TROKOMAT PLUS operates without any auxiliary fluids such as water or oil. The TROKOMAT PLUS is switched on and off hydraulically by means of water pressure and no other control is required. The automatic process is carried out by very few parts (image 1): this makes the TROKOMAT PLUS reliable and increases its durability. Even at low engine rpm the TROKOMAT PLUS starts the suction action. This reduces wear on the engine, especially when starting from cold. The fully automatic priming system TROKOMAT PLUS consists of two completely separately working short-stroke reciprocating pumps. The pistons are pressed by a spring against an eccentric pump shaft. If the

pump is engaged, the rotating eccentric pump shaft presses the pistons alternatively outwards. During this action air is drawn in from the suction line and housing. The springs press the pistons back towards the eccentric shaft. At the same time the intake air is compressed and routed to the atmosphere (image 2). The water entering into the primed pump overcomes the spring pressure and thus disengages the pistons from the eccentric shaft. The TROKOMAT PLUS switches off (image 3). If the pump pressure drops, the springs press the pistons against the eccentric shaft again and the priming resumes. The pump operator simply has to engage the pump and open the throttle.

200962/4/04/13/MA/1

OUR TROKOMAT PLUS.

PIECES

AIR

WATER

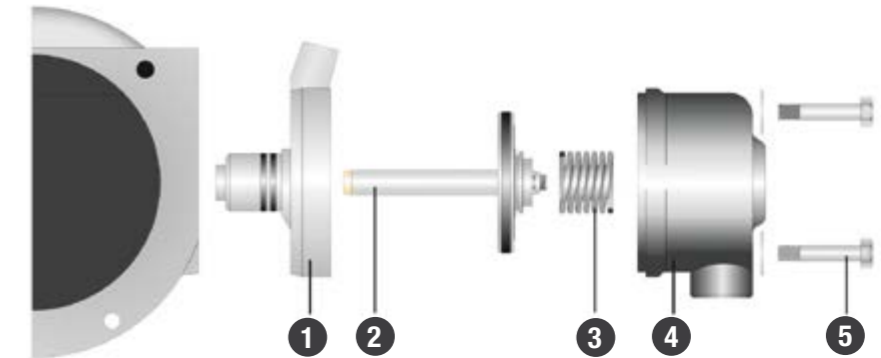

Image 1:

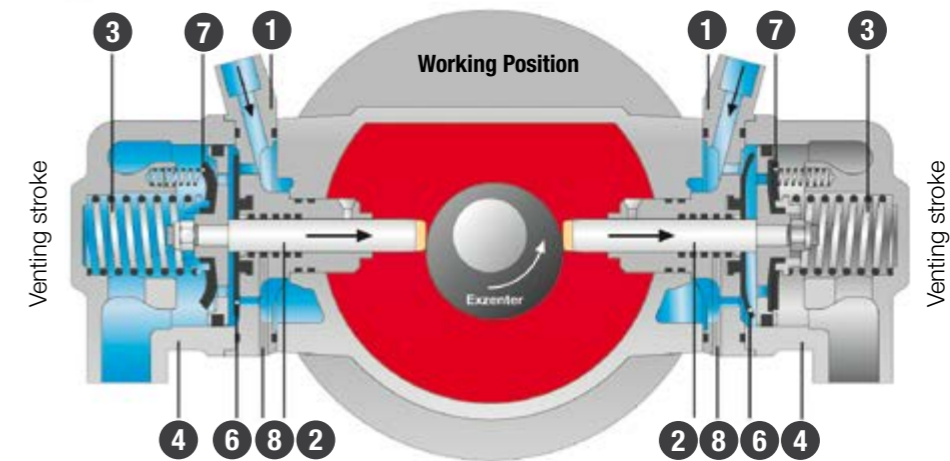

Image 2:

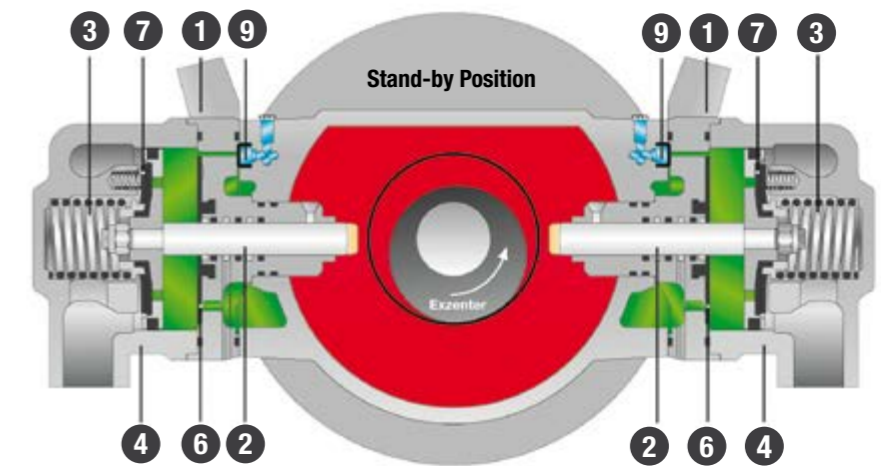

Image 3:

CAPTION:

- | | | | |
|---|-----------------|---|--------------------------------|
| 1 | Bearing flange | 6 | Inlet diaphragm |
| 2 | Piston, compl. | 7 | Outlet diaphragm |
| 3 | Pressure spring | 8 | Leakage water bore |
| 4 | Cylinder cap | 9 | Valve for resuming the priming |
| 5 | Heagon screw | | |